

Bulk material technology for the foodstuffs industry, grain industry, and non-food industries

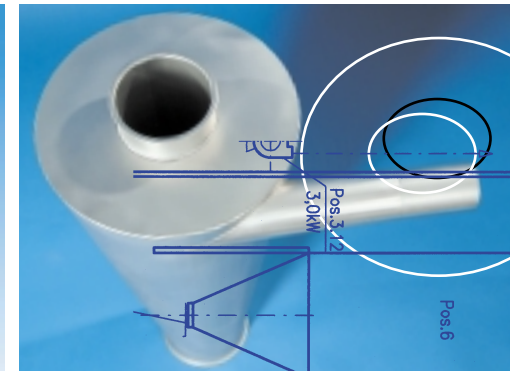
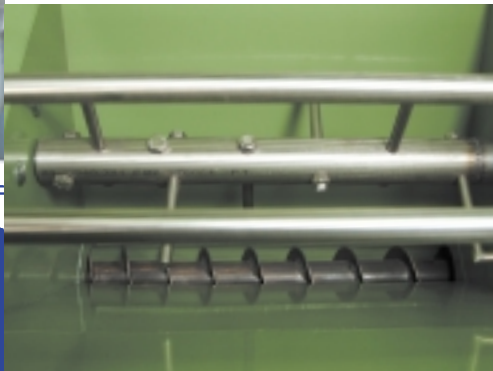
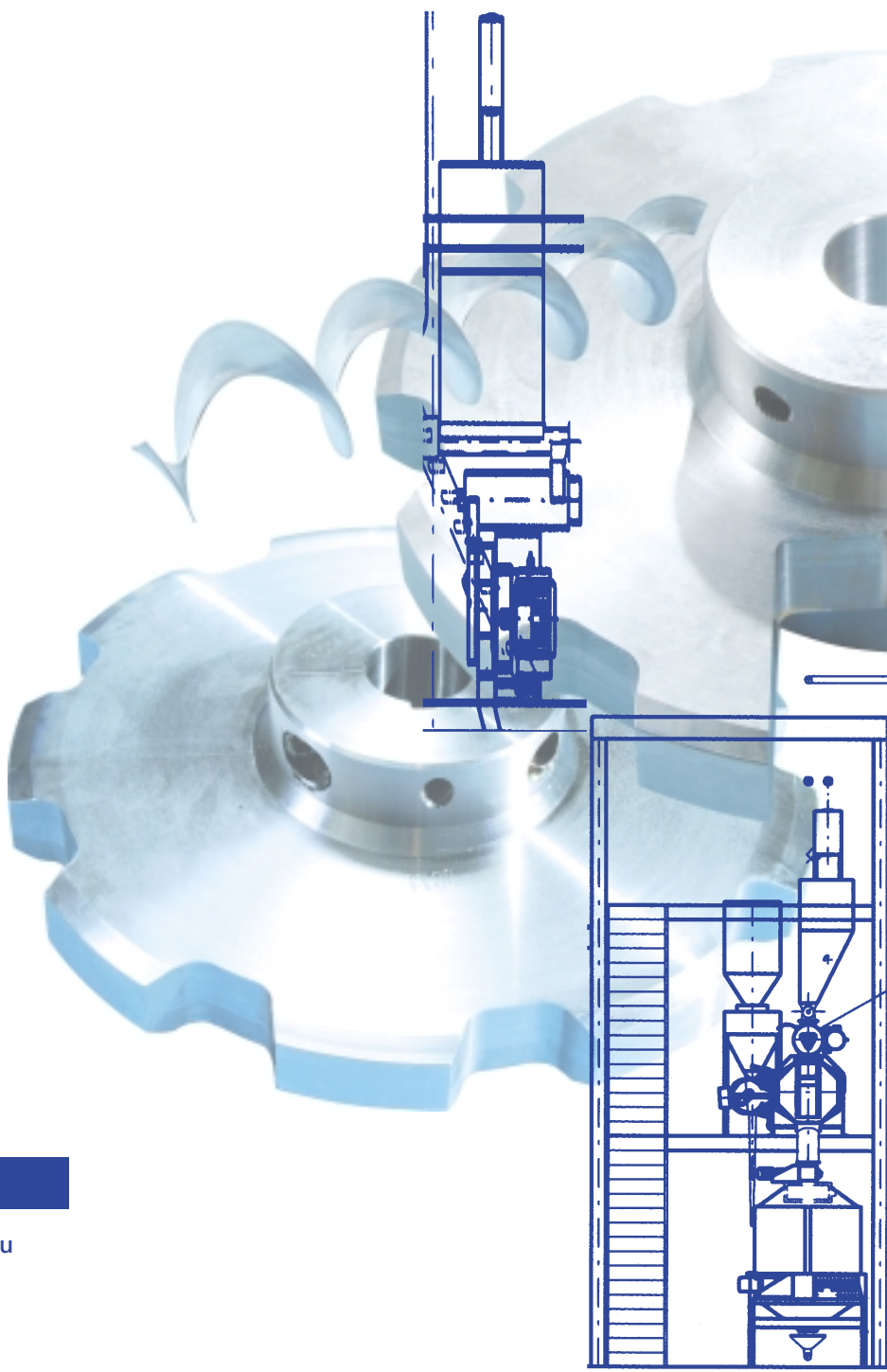

Paul Groth Mühlenbau
GmbH & Co. KG
Langelohe 2
D - 25337 Elmshorn

Tel. +49 (0) 41 21 - 79 57 - 0
Fax +49 (0) 41 21 - 79 57 - 79

E-mail: e-mail@paul-groth.com
www.paul-groth.com

PAUL GROTH
Mühlenbau GmbH & Co. KG

PAUL GROTH
Mühlenbau GmbH & Co. KG

A tradition of mill construction Decades of mobility

Broad expertise, proximity to customers and a mobile workforce have been the factors for our success since 1930.

■ As a medium-sized, family-owned company we continue, as we have always done in the past, to manufacture stand-alone machines and fit complete systems from the handling and processing of bulk materials to the final product.

Our extensive expertise in the field of mill and plant construction, our proximity to customers and a mobile workforce all have their roots in the company's history.

Paul Groth, Miller and Master Mill Builder, set the course for our company with the requisite pioneer spirit and entrepreneurial vision.



Christel Groth Diness on the trade show booth (1958)

His professionalism was acknowledged far and wide, both at home and abroad.

Together with his daughter Christel, he set up the company in Neumünster in 1948 after he had had to leave the business he founded in the 1920's in Pomerania.

The young company quickly became well respected for the repair of old mills and the building of new ones.

Success demanded more space so in 1960, the firm moved to new premises in Elmshorn. In 1965 Paul Groth's daughter, Christel Diness, took over the management of the business. Together with Master Miller Detlef Wiese, she competently

continued her father's legacy. Christel Diness's daughter, son and son-in-law (Annette, Niels and Andreas Diness) joined the family-owned business in the early 90's. In 1997 Christel Diness turned

the company over to her children. Niels and Andreas Diness took over the management of the company. With the support of highly motivated employees, the company has become even more strongly established in the field of mill and plant construction.



Paul Groth stands for personal customer orientation

At Paul Groth, personal and honest relationships with our customers are still our priority today.

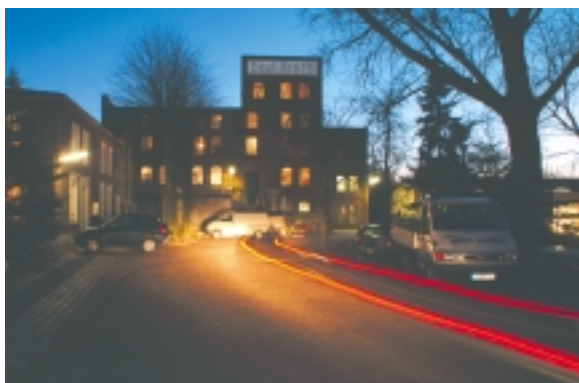

Always working for our customers: Paul Groth production, warehouse and offices at night.

Example of a complete silo system of glass fibre, reinforced plastic



■ Each customer is unique. This is the basis of our planning, order processing and product design. Our goal is to deliver a product that is the best solution for each customer.

Customer relationships of many years' standing, often over generations, motivate us to continue to widen our broad expertise, maintain our proximity to customers and increase our flexibility.

Your competent personal contact is at your service with products selected for your special requirements.

Directions to Paul Groth:

The company's headquarter is in Elmshorn and can easily be reached via main routes:

- From Hamburg, on the A23, take the Elmshorn exit
- From the north via the A7, take the Kaltenkirchen/ Elmshorn exit

With personal relationships and motivation - staying close to our customers is important to us

We have built our reputation on reliability, flexibility and personal relationships and use the experience gained in three industry sectors.

Our products are used in a broad range of applications. We supply the foodstuffs industry and the grain industry, as well as non-food industries. With experience gained over generations, we select the best and most economical solution for our customers, irrespective of the usual solutions.

We have both large and small customers and all of them receive the same courtesy and care.



Foodstuffs industry



Grain industry



Non-food industry



A list of the firms we work for include the following companies

- AGRAR GmbH Niepars
- Agrar Union GmbH
- Dairyfood Kaseinatwerk Kaltenkirchen GmbH
- Graf von Westphalen'sche Gutsverwaltungen
- J.J. Darboven GmbH & Co. KG
- Kaffee-Lagerei N.H.L. - Hirsch & Cons. (GmbH & Co. KG)
- Kraft Foods Deutschland GmbH
- Norddeutsche Pflanzenzucht Hans-Georg Lembke KG
- Nordgetreide GmbH & Co. KG
- Nordsaat Saatzucht-gesellschaft mbH Gutsverwaltung Granskevitz
- Peter Kölln KGaA
- Raiffeisen HaGe Nord AG
- Rudloff Feldsaaten GmbH
- SAMSUNG Engineering
- Schlüter & Maack GmbH & Co.

*All you millers far and wide,
from morning until eventide,
Work happy through the day
and never let a worry stay;
In times of trouble don't lose hope,
just get in touch with Mühlen-Groth,
Day or night you will see,
the machines he brings are quality.
He supplies them at a good low cost,
a skill the world seems to have lost.*

(Dedicated by Otto Plath,
Glanser Mill, 1938)

From the concept to the finished product – our customers are part of the team

We rely on dialogue and teamwork with the customer, thinking with you and planning the whole project with you.

■ We want to make it easy for you as the customer and from the very beginning, we have the operation and realisation of your objectives at heart. Your personal contact is committed to working just for you - from concept to commissioning.



The freedom of our employees to make their own decisions, together with our organisation, enable us to collaborate efficiently with our customers in a straight forward manner.

As one customer expressed it: We can often make the impossible possible.

We adapt our wide range of products and services to meet your particular requirements. For you as the customer, the road to the finished product is quite easy. Discuss your project with us on the phone, in our offices or at your site. We will submit a cost estimate and, after more precise planning, we will provide you with a detailed proposal.



We place particular value on discussions in a relaxed atmosphere.

Designing, handling sheet steel, drawing plants and diagrams.

Progressively equipped CAD workstations enable our mill construction personnel and draughtsmen to rapidly convert your sketched ideas into reality.

*Planning:
Overview drawings
Development of models and prototypes*



Components, stand-alone machines and the complete plant

We are a single source for consulting, planning and supply. Our fitters install, service, repair and optimise your plant.

Example of a complete site of round steel silos

Example of a filter plant with explosion protection



A single source for planning, supply and erection means easy interfacing and scheduled coordination, as well as logistical advantages in the execution.



Contact us if you require new plants, stand-alone machines or components, or if you would like to extend, restructure or increase capacity.

Are you in the market for used machines? With our good contacts, we can help. Our used machines are expertly reconditioned by our specialists.

Our services:

- Mechanical conveyor systems
- Pneumatic conveyor systems
- Cleaning and sifting
- Drying and cooling
- Pelletizing
- Storing
- Dust extraction
- Milling and mixing
- Dosing and weighing
- Ex-protection
- Safety-related fixtures

And here an example for a filter and cyclone system

Our fitters are versatile

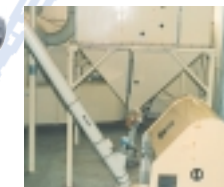

Our products are individually adapted to your specific application

Custom-tailored, economical solutions are produced from standard components with the potential to be adaptable



Doubled trough screw conveyor for the foodstuffs industry

We produce complete machines and stand-alone components for bulk goods systems, such as the entire conveyor technology, containers and slide valves – either painted, hot-dipped galvanized or in stainless steel. Starting with a diverse

range of products, we manufacture versions that are precisely tailored to your individual requirements.

Our employees and production facilities are also oriented to design and manufacture individual items within a reasonable timeframe.



Whether special components, standard components adapted to customer requirements or new designs, our in-house, high-performance manufacturing is flexible and safe.

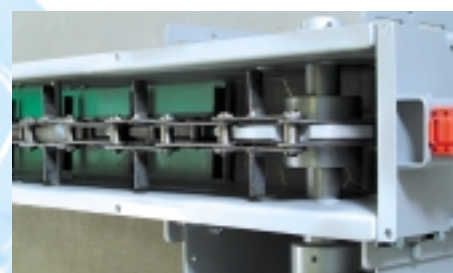
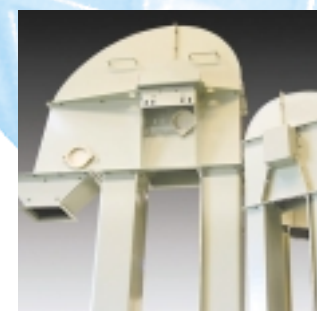

Often products are created simply from a requirement. Please talk to us!

The photos show examples from our manufacturing.

We supplement our strengths with trusted partners in the market

We offer ourselves as a flexible service provider in the field of bulk goods technology, supplemented by a proven track record of cooperation.

We stand by the quality and reliability of all our integrated supplier products.

■ We also cultivate long-term relationships with our suppliers and partners. This gives us mutually beneficial knowledge and experience of products, abilities and each others business. By doing this, we can utilise our respective strengths to optimise fulfilment of customer requirements and project coordination.



EUROPE'S No. 1 IN PIPE-WORK SYSTEMS

Every supplier is different but we ensure you receive quality. We source products and services from top manufacturers and companies, whose quality assurance and excellent service we have been familiar with for many years.

Our well-stocked warehouse includes (among other things) the largest assortment of original JACOB pipe parts in northern Germany.

We apply additional protection against wear and tear as required.

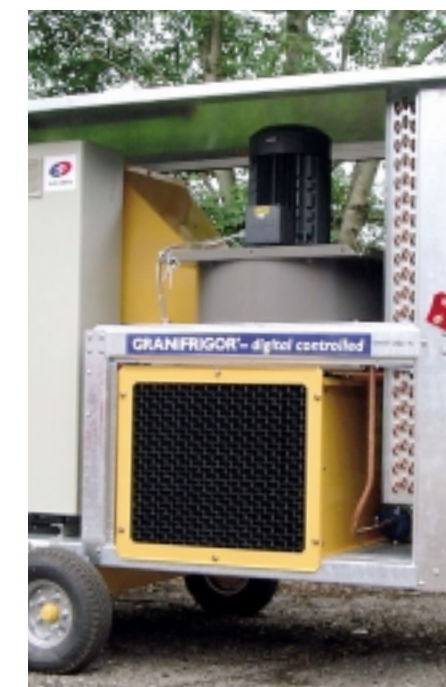
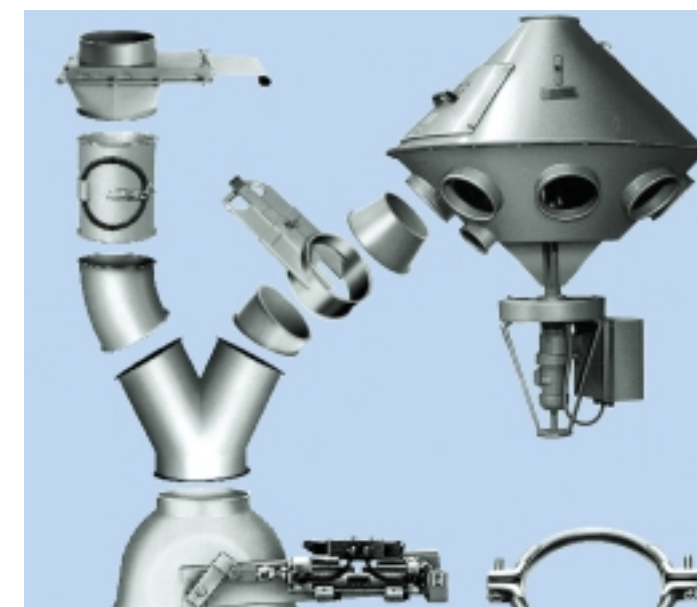

Axima GRANIFRIGOR® grain cooler for conservation of grain and rapeseed

We work with reliable specialists in the areas of:

- ▮ Pipe-work systems
- ▮ Grain coolers
- ▮ Filter technology
- ▮ Cleaning
- ▮ Drying
- ▮ Pelletizing
- ▮ Milling
- ▮ Silos
- ▮ Ex-protection



Our extensive stock of JACOB pipe-work offers immediate access to important parts. In accordance with the building set principle you can get downpipes, pipes for air conveying and dust extraction.

We manufacture for you the suitable transitions from your machine to the pipe-work system.

SALMATEC pellet presses for manufacturing all types of pellets, e.g. feed, wood chips, wastes.

